

Self-Clinch Studs

12-Rib Style

Flush Head

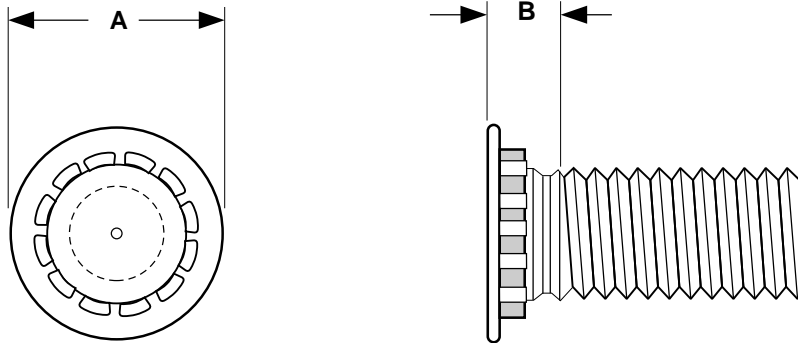

STEEL SELF-CLINCHING STUDS - 12-RIB STYLE WITH ANNULAR GROOVE									
Thread Size	A		B	Minimum Sheet Thickness	Hole in Sheet (+.003, -.000)	Distance to Center of Hole in Panel	Push-Out (lbs.)	Torque-Out (In.-lbs.)	Estimate of Installation Force in Steel
	Head Diameter		Unthreaded Length						Tons (Approx)
	Max	Min	Max			Min	#2 thru #10 diam based on .060 steel plates. 1/4 & 5/16 diam based on .088 steel plates.		
2-56	.156	.125	.075	.040	.085	.18	250	8.5	3
4-40	.204	.172	.085	.040	.111	.22	280	11	4
6-32	.219	.187	.090	.040	.137	.25	350	30	4.5
8-32	.250	.218	.090	.040	.163	.28	400	65	5
10-24	.266	.234	.100	.040	.189	.28	500	100	6
10-32	.266	.234	.100	.040	.189	.28	500	100	6
1/4-20	.344	.312	.135	.062	.249	.31	700	120	7
5/16-18	.391	.361	.160	.093	.311	.38	850	200	8
3/8-16	.460	.430	.165	.093	.375	.50			
1/2-13	.640	.630	.170		.502	.62			
Tolerance on Length				±.015					

Description	A fastener with unified thread pitch and a cylindrical, low profile head with small, rectangular ribs protruding from the underside of the head. The top of the head is flat and is flush with the mating surface when installation is complete. Below the ribs and above the first thread is an annular groove which helps to hold the fastener in position.	
Applications/ Advantages	Intended for metal panel-to-panel applications and well-suited for use in printed circuit boards. A hole is pierced into the circuit board and the unit it is attached to. The stud is inserted using a hand press or by hand, applying parallel squeezing forces. A hex nut is twisted onto the stud, securing it from the back. As the nut is tightened, the ribbed stud head grips the front panel to secure the application from the front as well, eliminating the need for welding. As the application force is applied, part of the sheet cold flows into an undercut under the head, making the fastener an integral part of the sheet.	
Material	<i>Steel</i> Low carbon steel	<i>Stainless</i> 300 series stainless
Heat Treatment	Clinch studs shall be case hardened, oil quenched and tempered.	
Case Hardness	Rockwell C 45 minimum	Not required to test for hardness
Core Hardness	Rockwell C 29 - 38	Not required to test for hardness
For Use In...	...materials with a hardness of Rockwell B80 or less.	...materials with a hardness of Rockwell B70 or less.
Finish	Steel clinch studs are usually furnished with a zinc plating.	Stainless clinch studs are commercially passivated.

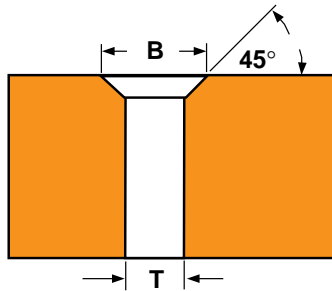

THIN SHEET ANVIL

Intended for panels less than 0.060" in thickness, with #4 thru #10 thread sizes, inclusive. Also, for panels less than 0.093" in thickness with 1/4" thread size.

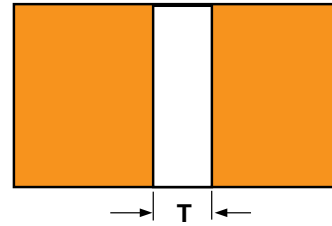

THICK SHEET ANVIL

Intended for panels 0.060" and greater in thickness, with #4 thru #10 thread sizes, inclusive. Also, for panels 0.093" and greater in thickness with 1/4" thread size.

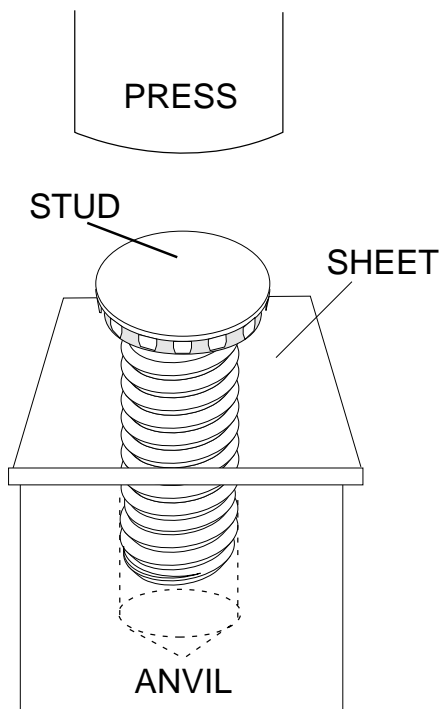

ANVIL DIMENSIONS		
Thread Size	Anvil	
	B	T
2-56	0.110	0.087
	0.114	0.090
4-40	0.136	0.113
	0.140	0.116
6-32	0.162	0.139
	0.166	0.142
8-32	0.188	0.165
	0.192	0.168
10-24 & 10-32	0.216	0.191
	0.220	0.194
1/4-20	0.295	0.250
	0.300	0.253
5/16-18	—	0.3125
	—	0.3155
3/8-16	—	
	—	

Notes on Installation: Apply only sufficient squeezing pressure to embed head of stud flush with panel. Do not use more pressure than necessary. Amount of pressure varies with panel material and size of stud. Studs install flush in sheets .040" or thicker but will project up to .020" in thinner sheets.

PART NUMBER COMPARISON - FLUSH HEAD CLINCH STUDS, STEEL								
Kanebridge	PEM	Captive	Kanebridge	PEM	Captive	Kanebridge	PEM	Captive
0208SCN	FH-256-8-ZI	CH 256-8	0648SCN	-	-	1114SCN	FH-032-14-ZI	CH 1032-14
0210SCN	FH256-10-ZI	CH 256-10	0804SCN	FH-832-4-ZI	CH 832-4	1116SCN	FH-032-16-ZI	CH 1032-16
0404SCN	FH-440-4-ZI	CH 440-4	0805SCN	FH-832-5-ZI	CH 832-5	1120SCN	FH-032-20-ZI	CH 1032-20
0405SCN	FH-440-5-ZI	CH 440-5	0806SCN	FH-832-6-ZI	CH 832-6	1124SCN	FH-032-24-ZI	CH 1032-24
0406SCN	FH-440-6-ZI	CH 440-6	0808SCN	FH-832-8-ZI	CH 832-8	1206SCN	-	-
0407SCN	-	-	0810SCN	FH-832-10-ZI	CH 832-10	1404SCN	-	-
0408SCN	FH-440-8-ZI	CH 440-8	0812SCN	FH-832-12-ZI	CH 832-12	1406SCN	FH-0420-6-ZI	CH 420-6
0410SCN	FH-440-10-ZI	CH 440-10	0814SCN	FH-832-14-ZI	CH 832-14	1408SCN	FH-0420-8-ZI	CH 420-8
0412SCN	FH-440-12-ZI	CH 440-12	0816SCN	FH-832-16-ZI	CH 832-16	1410SCN	FH-0420-10-ZI	CH 420-10
0414SCN	FH-440-14-ZI	CH 440-14	0820SCN	FH-832-20-ZI	CH 832-20	1412SCN	FH-0420-12-ZI	CH 420-12
0416SCN	-	-	0824SCN	FH-832-24-ZI	CH 832-24	1414SCN	FH-0420-14-ZI	CH 420-14
0418SCN	-	-	0832SCN	-	-	1416SCN	FH-0420-16-ZI	CH 420-16
0424SCN	-	-	1006SCN	FH-024-6-ZI	CH 024-6	1418SCN	FH-0420-18-ZI	CH 420-18
0504SCN	-	-	1008SCN	FH-024-8-ZI	CH 024-8	1420SCN	FH-0420-20-ZI	CH 420-20
0516SCN	-	-	1010SCN	FH-024-10-ZI	CH 1024-10	1424SCN	FH-0420-24-ZI	CH 420-24
0604SCN	FH-632-4-ZI	CH 632-4	1012SCN	FH-024-12-ZI	CH 1024-12	1432SCN	-	-
0605SCN	FH-632-5-ZI	CH 632-5	1014SCN	FH-024-14-ZI	CH 1024-14	1512SCN	-	-
0606SCN	FH-632-6-ZI	CH 632-6	1016SCN	FH-024-16-ZI	CH 1024-16	3110SCN	FH-0518-10-ZI	CH 518-10
0608SCN	FH-632-8-ZI	CH 632-8	1020SCN	FH-024-20-ZI	CH 1024-20	3112SCN	FH-0518-12-ZI	CH 518-12
0610SCN	FH-632-10-ZI	CH 632-10	1024SCN	FH-024-24-ZI	CH 1024-24	3114SCN	FH-0518-14-ZI	CH 518-14
0612SCN	FH-632-12-ZI	CH 632-12	1104SCN	-	CH1032-4	3116SCN	FH-0518-16-ZI	CH 518-16
0614SCN	FH-632-14-ZI	CH 632-14	1105SCN	FH-032-5-ZI	CH 1032-5	3120SCN	FH-0518-20-ZI	CH 518-20
0616SCN	FH-632-16-ZI	CH 632-16	1106SCN	FH-032-6-ZI	CH 1032-6	3124SCN	FH-0518-24-ZI	CH 518-24
0620SCN	FH-632-20-ZI	CH 632-20	1108SCN	FH-032-8-ZI	CH 1032-8	3128SCN	-	-
0624SCN	FH-632-24-ZI	CH 632-24	1110SCN	FH-032-10-ZI	CH 1032-10	3132SCN	-	-
0632SCN	-	-	1112SCN	FH-032-12-ZI	CH 1032-12	3716SCN	-	-

PART NUMBER COMPARISON - FLUSH HEAD CLINCH STUDS, STAINLESS								
Kanebridge	PEM	Captive	Kanebridge	PEM	Captive	Kanebridge	PEM	Captive
0604SCN300	FHS-632-4	CHS 632-4	0824SCN300	FHS-832-24	CHS 832-24	1408SCN300	FHS-0420-8	CHS 420-8
0605SCN300	FHS-632-5	CHS 632-5	1006SCN300	FHS-024-6	CHS 1024-6	1410SCN300	FHS-0420-10	CHS 420-10
0606SCN300	FHS-632-6	CHS 632-6	1008SCN300	FHS-024-8	CHS 1024-8	1412SCN300	FHS-0420-12	CHS 420-12
0608SCN300	FHS-632-8	CHS 632-8	1010SCN300	FHS-024-10	CHS 1024-10	1414SCN300	FHS-0420-14	CHS 420-14
0610SCN300	FHS-632-10	CHS 632-10	1012SCN300	FHS-024-12	CHS 1024-12	1416SCN300	FHS-0420-16	CHS 420-16
0612SCN300	FHS-632-12	CHS 632-12	1016SCN300	FHS-024-16	CHS 1024-16	1420SCN300	FHS-0420-20	CHS 420-20
0616SCN300	FHS-632-16	CHS 632-16	1106SCN300	FHS-032-6	CHS 1032-6	1424SCN300	FHS-0420-24	CHS 420-24
0806SCN300	FHS-832-6	CHS 832-6	1108SCN300	FHS-032-8	CHS 1032-8	1432SCN300	-	-
0808SCN300	FHS-832-8	CHS 832-8	1110SCN300	FHS-032-10	CHS 1032-10	3110SCN300	FHS-0518-10	CHS 518-10
0810SCN300	FHS-832-10	CHS 832-10	1112SCN300	FHS-032-12	CHS 1032-12	3112SCN300	FHS-0518-12	CHS 518-12
0812SCN300	FHS-832-12	CHS 832-12	1116SCN300	FHS-032-16	CHS 1032-16	3116SCN300	FHS-0518-16	CHS 518-16
0816SCN300	FHS-832-16	CHS 832-16	1120SCN300	FHS-032-20	CHS 1032-20	3120SCN300	FHS-0518-20	CHS 518-20
0820SCN300	FHS-832-20	CHS 832-20				3124SCN300	FHS-0518-24	CHS 518-24

PEM® is a registered trademark of Penn Engineering and Manufacturing Corporation. Kanebridge's clinch studs are not manufactured by or connected with the producers of PEM® clinch studs.