

ADDITIONAL PRODUCTS

PARKING STOPS

Checkers Parking Stops replace unsightly, old, concrete parking stops with 100% recycled solid plastic. They will not chip or crack like concrete and withstand abuse from gas, oil, salt, sunlight and chemicals. Parking Stops are molded in solid colors and never need painting. Checkers Parking Stops are maintenance free and can be installed by one person.

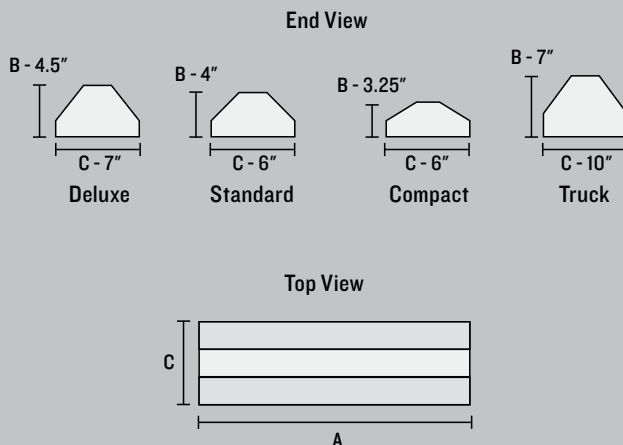

NOTE: Please make your product selection carefully. Parking Stops are non-returnable. All dimensions are nominal – allow for up to 3-6% mold shrinkage.

	MODEL W/ HARDWARE	MODEL W/O HARDWARE	DESCRIPTION	A: LENGTH	B: HEIGHT	C: WIDTH	WEIGHT
4 FT. CAR PARKING STOPS	CS4S-H*	CS4S	Standard 4 ft. Car Parking Stop	48 in. (121.9 cm)	4 in. (10.2 cm)	6 in. (15.2 cm)	20 lb. (9.1 kg)
	CS4D-H*	CS4D	Deluxe 4 ft. Car Parking Stop	48 in. (121.9 cm)	4.5 in. (11.5 cm)	7 in. (17.9 cm)	24 lb. (10.9 kg)
6 FT. CAR PARKING STOPS	CS6C-H*	CS6C	Compact 6 ft. Car Parking Stop	72 in. (182.9 cm)	3.25 in. (8.3 cm)	6 in. (15.2 cm)	25 lb. (11.4 kg)
	CS6S-H*	CS6S	Standard 6 ft. Car Parking Stop	72 in. (182.9 cm)	4 in. (10.2 cm)	6 in. (15.2 cm)	30 lb. (13.6 kg)
	CS6D-H*	CS6D	Deluxe 6 ft. Car Parking Stop	72 in. (182.9 cm)	4.5 in. (11.5 cm)	7 in. (17.9 cm)	36 lb. (16.4 kg)
8 FT. TRUCK PARKING STOPS	TS8-H*	TS8	8 ft. Truck Parking Stop	96 in. (244.8 cm)	7 in. (17.9 cm)	10 in. (25.5 cm)	100 lb. (45.5 kg)

* Specify color after Model No.: Y = Yellow; G = Grey; B = Blue; ALSO specify hardware selection: L = Lag Screws; S = Steel Spikes

MOUNTING HARDWARE SELECTION GUIDE

NOTE: One set of Mounting Hardware is included at no additional charge with each Parking Stop purchased. Please specify type of hardware desired based on installation to either concrete or asphalt.

HARDWARE PACKAGE (CHOOSE ONE)	APPLICATION	PRODUCT	LAG SCREWS**	EXPANDING LAG SHIELDS	FLAT WASHERS (0.5 IN.)	STEEL SPIKES***
Lag Bolt Hardware	Recommended for concrete where drilling holes is permitted	4' Car Parking Stop	2	2	4	-
		6' Car Parking Stop	3	3	6	-
		8' Truck Parking Stop	4	4	8	-
Steel Spike Hardware	Recommended for asphalt surfaces	4' Car Parking Stop	-	-	-	2
		6' Car Parking Stop	-	-	-	3
		8' Truck Parking Stop	-	-	-	4

** Lag Screws are 0.5 x 8 in. for Car Parking Stops, and are 0.5 x 10 in. for Truck Parking Stops.

*** Steel Spikes are 0.5 in. x 12 in. w/ 1.125" head.

ADDITIONAL PRODUCTS

SPEED BUMPS

Checkers 100% recycled plastic Speed Bumps alert drivers to potentially hazardous driveways and parking areas. Speed Bumps will not chip or crack under heavy loads and withstand abuse from gas, oil, salt, sunlight and chemicals. Molded in solid colors, speed bumps never need painting. Checkers Speed Bumps are maintenance free and can be installed by one person.

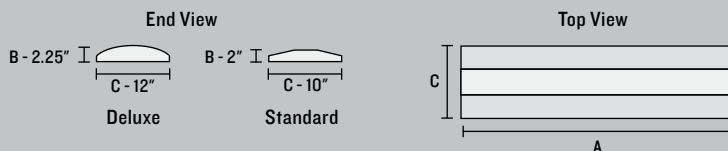

NOTE: Please make your product selection carefully. Speed Bumps are non-returnable. All dimensions are nominal – allow for up to 3-6% mold shrinkage.

	MODEL W/ HARDWARE	MODEL W/O HARDWARE	DESCRIPTION	A: LENGTH	B: HEIGHT	C: WIDTH	WEIGHT	COLOR
4 FT. SPEED BUMPS	SB4S-H*	SB4S	Standard 4 ft. Speed Bump	48 in. (121.9 cm)	2 in. (5.1 cm)	10 in. (25.5 cm)	22 lb. (10 kg)	Yellow
	SB4D-H*	SB4D	Deluxe 4 ft. Speed Bump	48 in. (121.9 cm)	2.25 in. (5.8 cm)	12 in. (30.6 cm)	28 lb. (12.7 kg)	Yellow
6 FT. SPEED BUMPS	SB6S-H*	SB6S	Standard 6 ft. Speed Bump	72 in. (182.9 cm)	2 in. (5.1 cm)	10 in. (25.5 cm)	25 lb. (11.4 kg)	Yellow
	SB6D-H*	SB6D	Deluxe 6 ft. Speed Bump	72 in. (182.9 cm)	2.25 in. (5.8 cm)	12 in. (30.6 cm)	41 lb. (18.6 kg)	Yellow
9 FT. SPEED BUMPS	SB9S-H*	SB9S	Standard 9 ft. Speed Bump	108 in. (275.4 cm)	2 in. (5.1 cm)	10 in. (25.5 cm)	50 lb. (22.7 kg)	Yellow

* Specify hardware selection: L = Lag Screws; S = Steel Spikes

MOUNTING HARDWARE SELECTION GUIDE

NOTE: One set of Mounting Hardware is included at no additional charge with each Speed Bump purchased. Please specify type of hardware desired based on installation to either concrete or asphalt.

HARDWARE PACKAGE (CHOOSE ONE)	APPLICATION	PRODUCT	LAG SCREWS**	EXPANDING LAG SHIELDS	FLAT WASHERS (0.5 IN.)	STEEL SPIKES***
Lag Bolt Hardware	Recommended for concrete where drilling holes is permitted	4' Speed Bump	3	3	6	-
		6' Speed Bump	4	4	8	-
		9' Speed Bump	5	5	10	-
Steel Spike Hardware	Recommended for asphalt surfaces	4' Speed Bump	-	-	-	3
		6' Speed Bump	-	-	-	4
		9' Speed Bump	-	-	-	5

* Lag Screws are 0.5 x 5.5 in. ** Steel Spikes are 0.5 in. x 12 in. w/ 1.125" head

GOGGLE RETAINERS

Checkers Goggle Retainers are designed for use where protective eyewear must be worn with a safety hat or cap. These retainers install quickly and easily with no tools required. Goggle retainers will retain the goggle on the safety hat or cap when the goggle is not in use, and hold the goggle securely when worn for eye protection. Goggles, cap or hat not included.



GR9562 CAP MODEL



GR9662 HAT MODEL

*Goggles, cap or hat not included

WARNING: Goggles will come off and eye protection will be eliminated if helmet becomes dislodged or is knocked off wearer's head. Wear helmet chin straps or retain goggles separately if this potential exists. Do not use where contact with direct or open flames exists. FAILURE TO COMPLY WITH THE ABOVE CAUTION CAN CAUSE LOSS OF EYE PROTECTION AND RESULT IN EYE INJURY.

MODEL	DESCRIPTION	COLOR	QUANTITY
GR9562	Goggle Retainer for Cap	Black	50/Case
GRB1018	Replacement Elastic Cord for Cap Retainer	Black	10/Pack
GR9662	Goggle Retainer for Hat	Black	50/Case
GRB1021	Replacement Elastic Cord for Hat Retainer	Black	10/Pack